

Keeping **Shrink-Wrapping** Simple



02 9452-3566
sales@getpacked.com.au



Hand Held Shrinkwrap Unit Operating Instructions

All personnel must read the following operating instructions. Before proceeding please check gas bottle outlet is clean as this is the most common cause of failure. Connect regulator into gas outlet and hose to regulator (both left hand threads) – see fig.1. Connect shrink gun to other end of hose (also left hand thread) see fig.2.

Turn on gas and slowly press the excess flow check valve to charge the system with gas (see fig.1).

Inspect connections for leaks (see Hazards & Safety Instructions – 4). Point the gun towards a clear area of the floor and squeeze the trigger slowly. It is possible that the gun will ignite with only one small squeeze of the trigger, especially if it is warm and the operator has had a small amount of practice. The trigger must be depressed to maintain the flame.



Shrinkwrap Unit in Operation Hazards and Safety Instructions

- 1 Instruction in the safe operation of system must be given before any person is permitted to use the equipment.
- 2 Only trained personnel should operate the system.
- 3 Be sure to use a gas bottle with vapour only withdrawal.
- 4 Gas tight joints must be maintained. Always check the hose and connections for leaks before use; there is an aerosol spray 'leak detection' available (or a soapy liquid brushed on joints will quickly detect leaks).
- 5 **NEVER** use the system with a damaged hose, regulator etc.
- 6 Suitable gloves must be worn.
- 7 The gun should not be used in hazardous situations, i.e. inflammable or dust-laden areas.

- 8 Care should be taken to ensure the gas bottle is not pulled along by the hose.
- 9 **NEVER DIRECT GUN TOWARDS ANY OTHER PERSONNEL.**
- 10 **NEVER LOOK IN BURNER OPENING WHEN GUN IS CONNECTED.**
- 11 **ALWAYS** ensure gas supply has been turned off correctly and any excess gas has been burned off before leaving gun unattended.
- 12 **NEVER** lay the gun on the floor. Always hang the gun up using the eyelet provided (see fig.6).
- 13 **NEVER** hold gun in the vertical position when shrinking top surfaces as rising heat can cause an unstable flame (*see illustration above).
- 14 The mixer **MUST** be fitted a minimum of 19mm into the burner (see fig. 8).

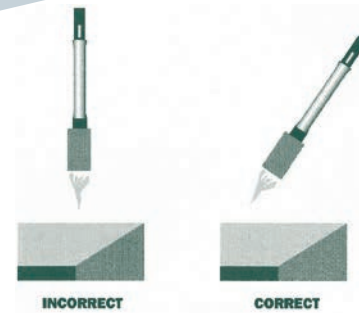

Location and Ventilation for Shrinkwrapping

- (i) Area for shrink-wrapping must be oil, grease and dust free and clear of all combustible material. The operator must ensure no objects will interfere with the operation of the shrink gun.
- (ii) Some consideration should be given to the erection of non-combustible screens around the area of operation.
- (iii) The shrink gun should be operated in a well-ventilated area, to ensure good all round airflow when shrink-wrapping.

Fire Extinguishers

- (i) Suitable extinguishers should be available for immediate use at site of operation.

PLEASE NOTE: Failure to comply to any of the above instructions, including tampering with or dismantling of the gun, will invalidate your warranty. If you have any problems or queries regarding your shrink system, please contact your supplier.

IMPORTANT
When having to replace the original handle, care must be taken to ensure that the earth terminal on the spark generator is touching the barrel.

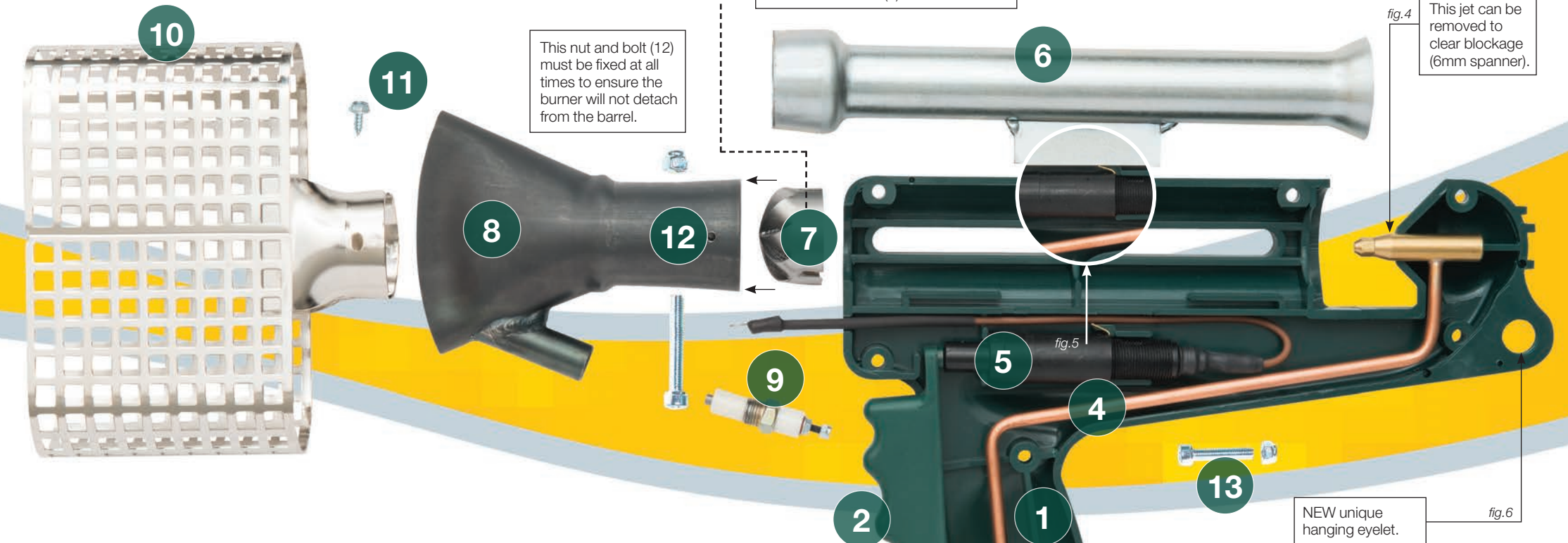
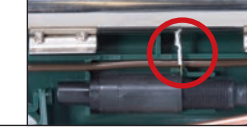

Hand Held Shrinkwrap Unit

IMPORTANT
This unit must be run on a minimum of 3.5 Bars (50psi) or overheating and damage may occur.

1. Handle	9. Electrode
2. Trigger	10. Cowl
3. Valve	11. Cowl stabilising screw
4. Jet pipe assembly	12. Burner and Cowl fixing nut and bolt
5. Spark generator (lead assembly)	13. Handle assembly nuts & bolts (8)
6. Barrel	14. Regulator (not shown)
7. Mixer	15. Hose (not shown)
8. Burner	

Keeping Shrink-Wrapping Simple

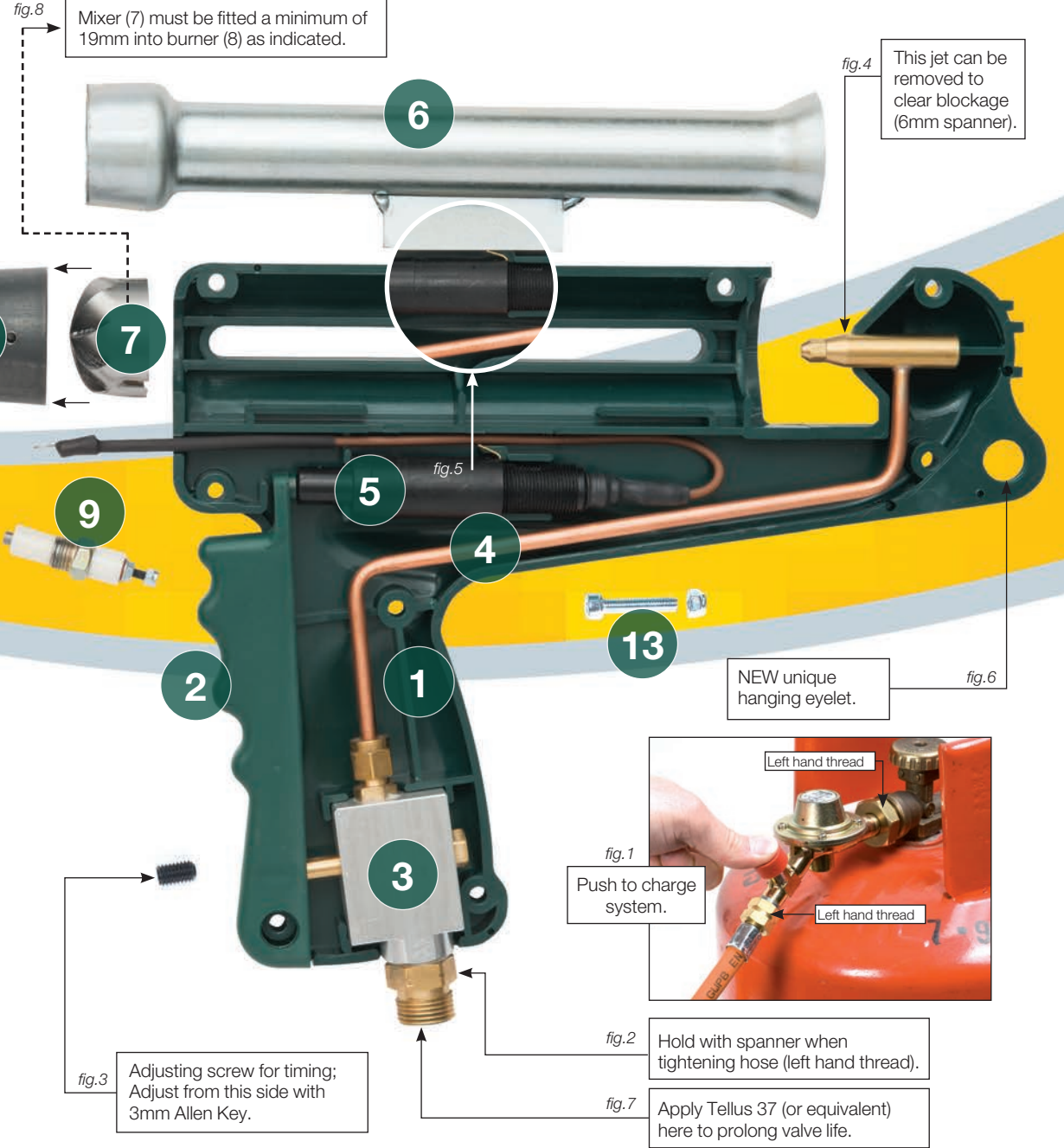

Shrink Wrap Unit Maintenance Guide

Maintenance – Must only be carried out by an experienced gas fitter.

A regular drop of oil (as supplied) into the valve at the hose connection (see fig.7) will prolong valve life. Blow dirt from inside the barrel at regular intervals as reduced air flow will cause overheating and an irregular flame. Gas tight joints must be maintained. Always check the hose and connections for leaks before use.

Fault Finding Chart

Problem	Possible Cause
Gun not firing	Gas supply not on. Excess flow check valve not primed (see fig. 1). Damaged electrode. Gas valve adjustment screw not operating plunger (see fig.3). Defective spark generator. Earth strip on spark generator not touching barrel stabilizer (see fig.5).
Gas has yellow flame	Gas pressure too low. Dirt in barrel. Blocked jet (see fig.4). Gas leak in body. Blocked valve. Iced supply.
Large flame	Pressure too high. Jet too large (see fig.4). Blocked or damaged mixer.
Constant gas	Gas valve adjusting screw tight against plunger (see fig.3) or valve sticking.

The benefits below and many more are available to you by adopting one of our shrink-wrap systems. For further information on how to purchase please call or email our marketing division today.

Improved Load Stability

Weather Protection

Outside Storage

Identifiable Contents

Dust Protection

Pilferage Deterrent

Shrink-wrapping system comprising of:

1. Shrink Wrap Gun
2. 8 Metre Hose
3. Regulator Hose Failure Valve
4. Oil Bottle (including oil)
5. Operation Instructions
6. Spanners** (optional extra)
7. 6 Month Warranty

Environmentally Friendly:

 Please note polythene is 100% recyclable (if clean). Our shrink guns are 95% recyclable.



Technical Data	
Fuel	Propane vapour
Fuel Container	Industrial gas bottle
Ignition	Piezo crystal
Gas Pressure	3.5 bars (50 psi)
Heat Variable	32kw (110,000 BTU)
Gas Consumption	2kg/hr (5lb/hr)
Weight	1kg approximately
Hose Lengths	8 metres (26 feet)
Burner Safety	Dead man's handle
Regulator	Excess failure valve
Maintenance	Occasional drop of oil as supplied

Our improved systems are stronger, more powerful, easy to operate and comfortable to handle, economical, reliable and safe. The nozzle is protected by an integral heat shield and the propane gas flow helps keep the burner cool. Supplied in complete kits as mentioned above, or the shrink guns are available to buy as single units.



02 9452-3566
sales@getpacked.com.au