

- 1** LIFT TENSION FLAPS 'A' AND SLIDE PRODUCT UNDER FILM.

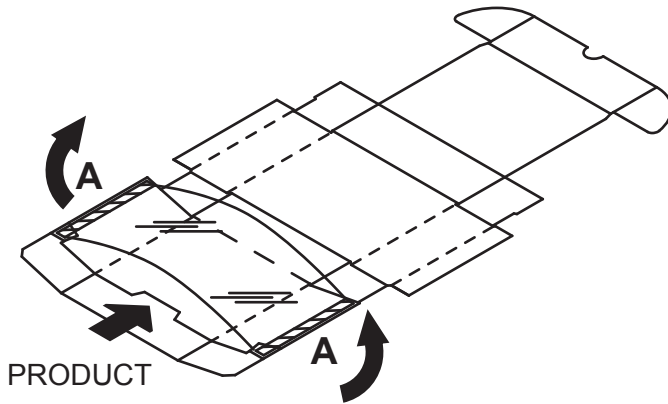

- 2** FOLD BOTH FLAPS 'A' WITH EQUAL FORCE DOWN AND UNDER PANEL 'C'.

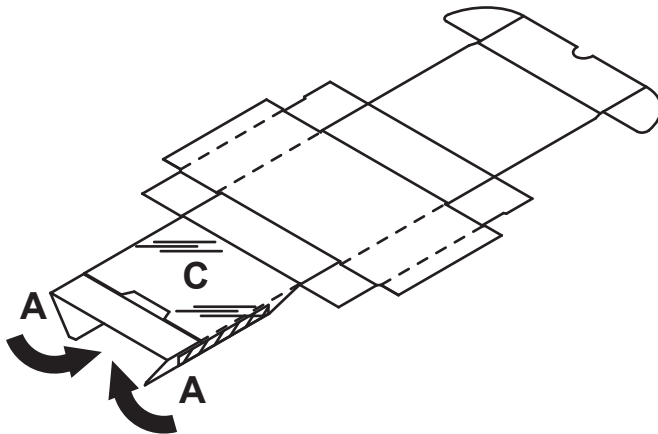

- 3** LOCK THE TAB IN PLACE BY FOLDING PANEL 'B'. ROLL PANEL 'C' OVER PANEL 'D'.

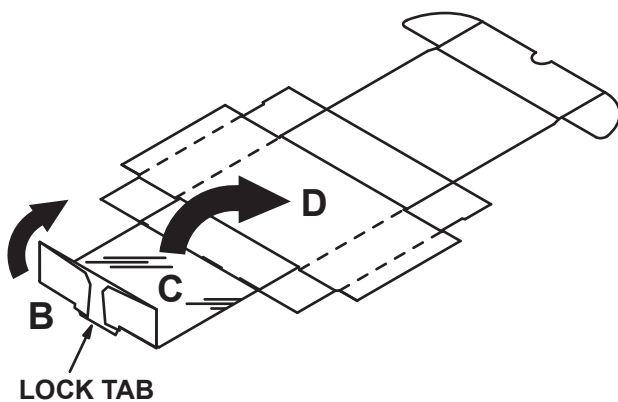

- 4** FOLD SMALLER FLAPS TOWARDS THE MIDDLE OF THE BOX.

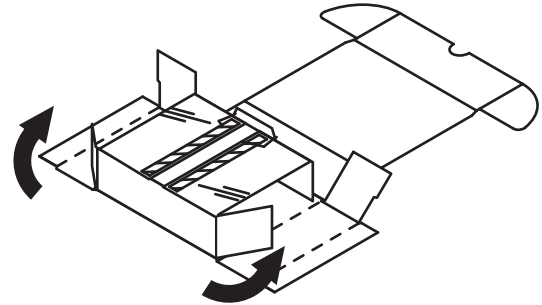

- 5** FOLD SIDE PANELS 'E' AND RAILS 'F' OVER THE TOP. FOLD REMAINING FLAPS TOWARDS THE MIDDLE.

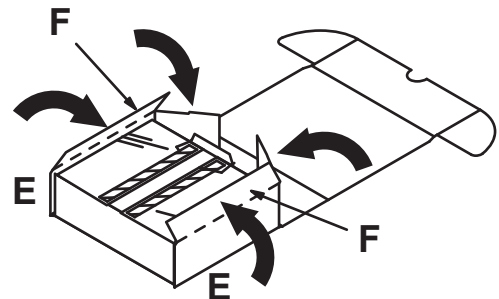

- 6** ROLL PANEL 'G' OVER THE TOP AND TUCK FLAPS INTO SIDE SLOTS.

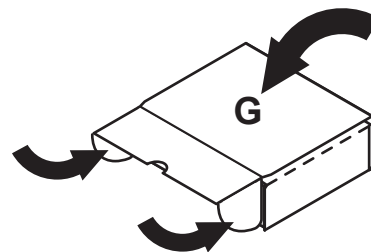

1 BOX ASSEMBLY - FOLD CORNER FLAPS TOWARDS MIDDLE OF BOX.

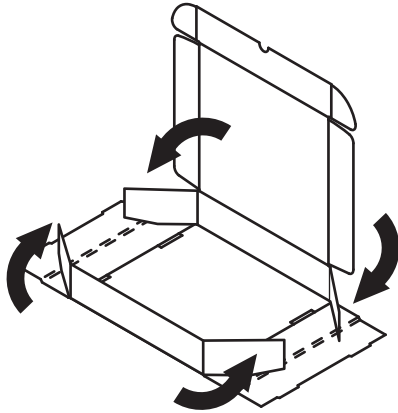

2 FOLD SIDE FLAPS UP AND THEN OVER TO MEET SLOTS AT THE BOTTOM. LOCK IN PLACE.

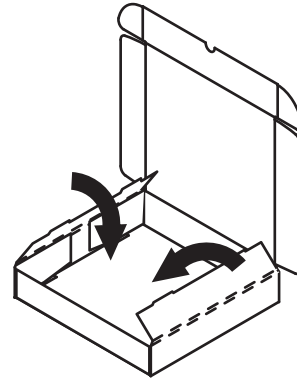

3 FRAME ASSEMBLY - FOLD TENSION FLAPS AND LIFT FILM. INSERT PRODUCT.

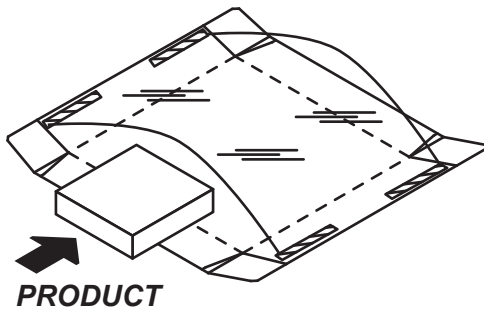

4 FOLD BOTH FLAPS WITH EQUAL FORCE DOWN AND UNDER THE FRAME.

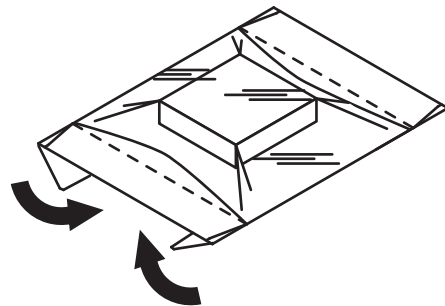

5 FOLD SIDE PANELS UP 90 DEGREES AND HOLD TOGETHER.

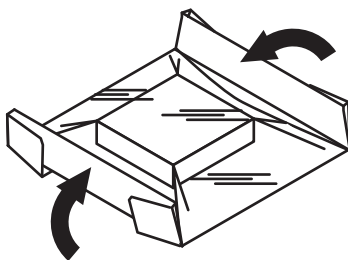

6 HOLD PANELS TOGETHER AND INSERT INTO BOX. FOLD IN DUST FLAPS AND CLOSE BOX.

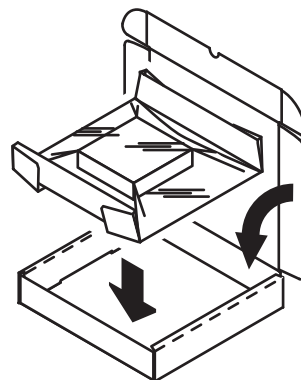

- 1** PLACE ACCESSORIES ON THE BOTTOM OF THE BOX.

ACCESSORIES

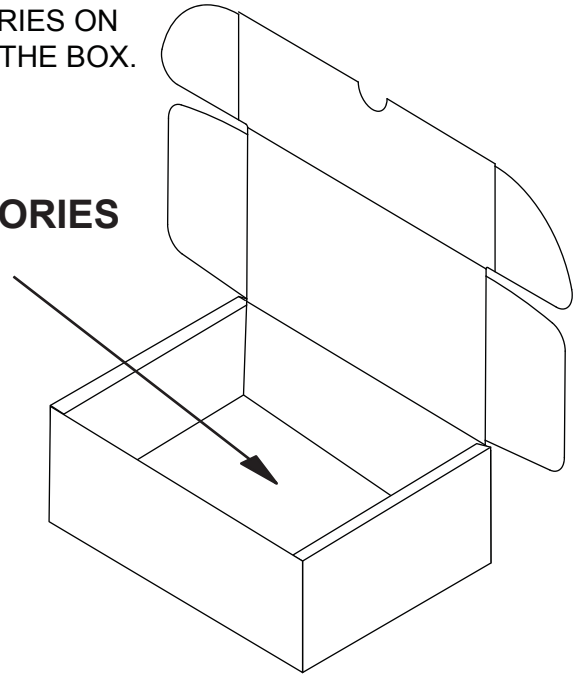

- 2** FOLD TENSION FLAPS UP TO RELEASE FILM. LIFT FILM AND INSERT PRODUCT.

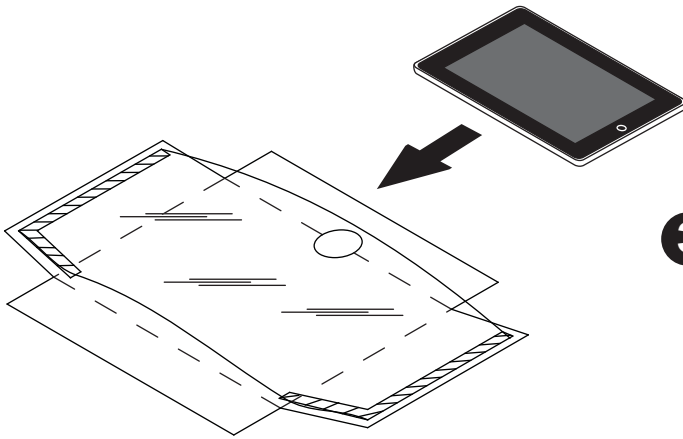

- 3** FOLD TENSION FLAPS DOWN AT 90° ANGLE.

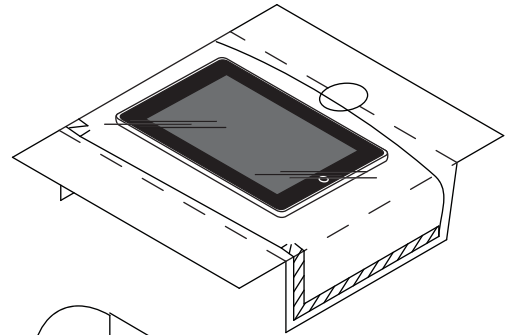

- 4** FOLD END LEG PANELS UP AND HOLD IN PLACE WHILE INSERTING INTO THE BOX OVER THE ACCESSORIES.

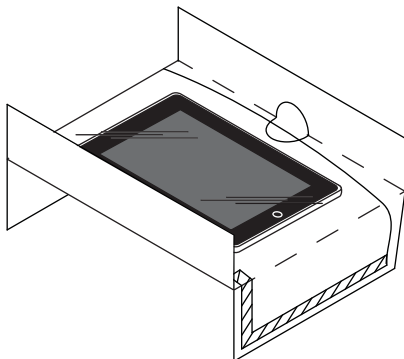

ACCESSORIES

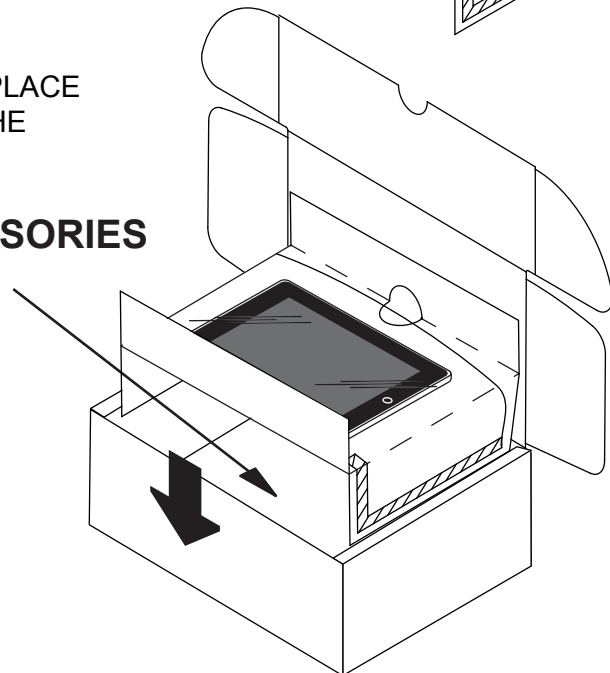

- 1** FOLD TENSION FLAPS UP TO RELEASE FILM.
LIFT FILM AND INSERT PRODUCT.

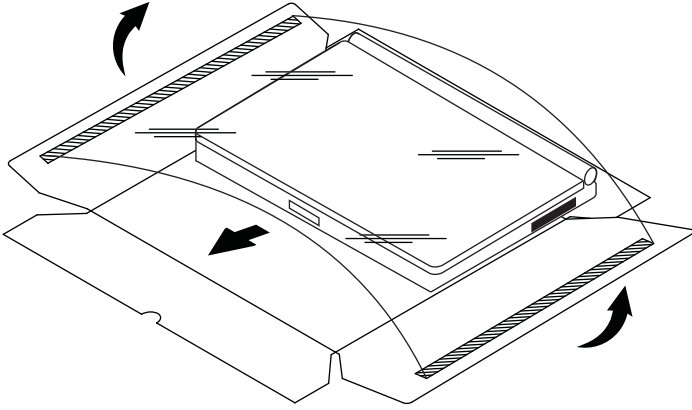

- 2** FOLD TENSION FLAPS DOWN AND UNDER BASE.

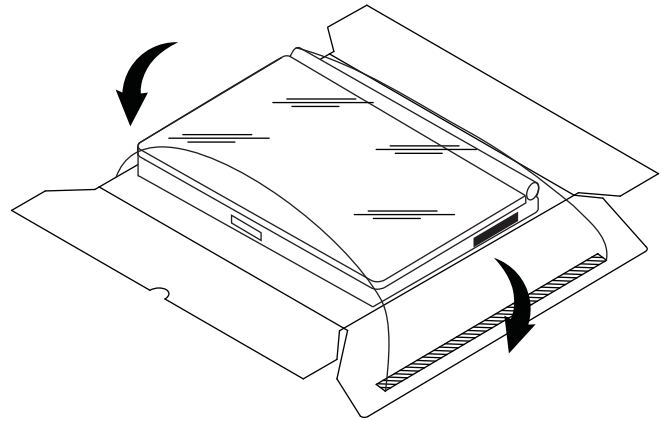

- 3** FOLD END PANELS UP AND HOLD IN PLACE
WHILE INSERTING INTO THE BOX. PLACE
ACCESSORIES BEHIND PANEL WITH HALF MOON.

ACCESSORIES

