

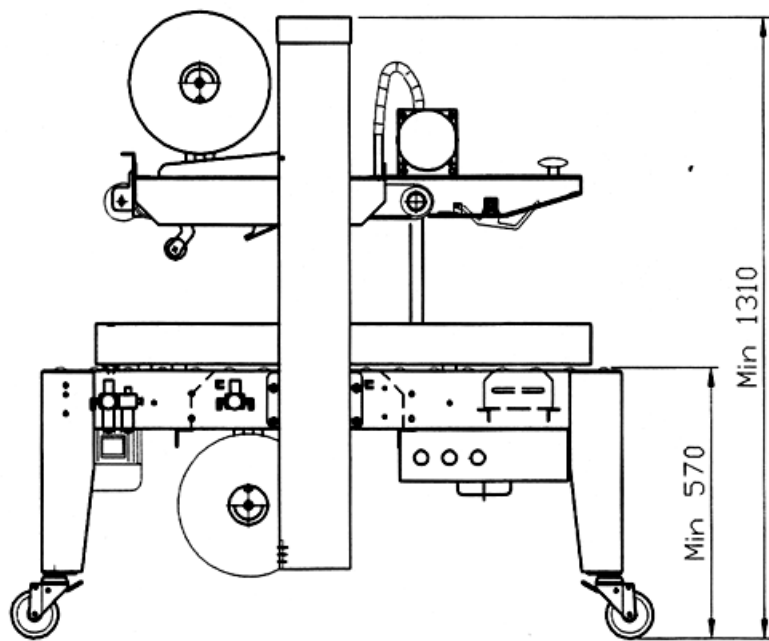

MATCH FOR PACK

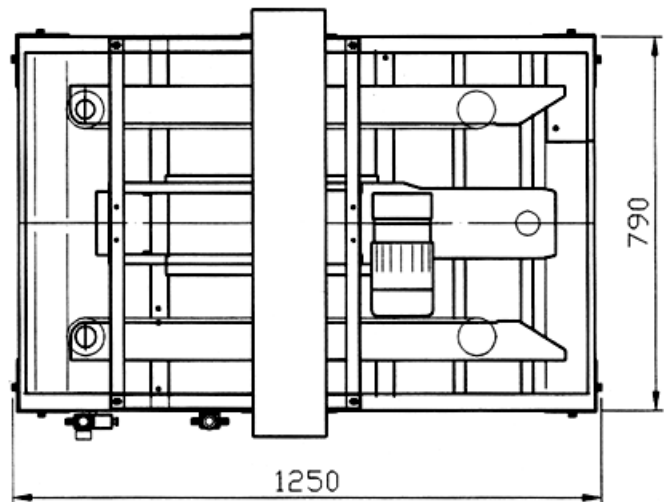

**EC-702A
FULL AUTO RANDOM CARTON
SEALER**



規格表				
機 型	EC-702A			
機械尺寸	(L)1250mmx (W)902mmx (H)1310mm			
枱面高度	570~780mm			
可包裝尺寸	(L)150~mmx(W)100~500mmx(H)100~500mm			
膠帶寬度	2"(2-1/2", 3" option)			
封箱速度	60Hz	22M/Min	50Hz	18M/Min
電 源 (AC)	單相 3相	100/110/220 220/380 V	60/50Hz	150Wx3=450W
重 量	淨重	132Kg	毛重	170Kg
傳動方式	左右及上座三個馬達傳動			

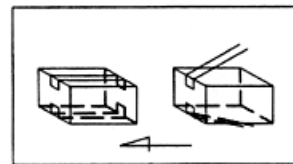
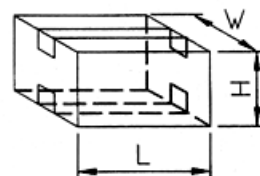
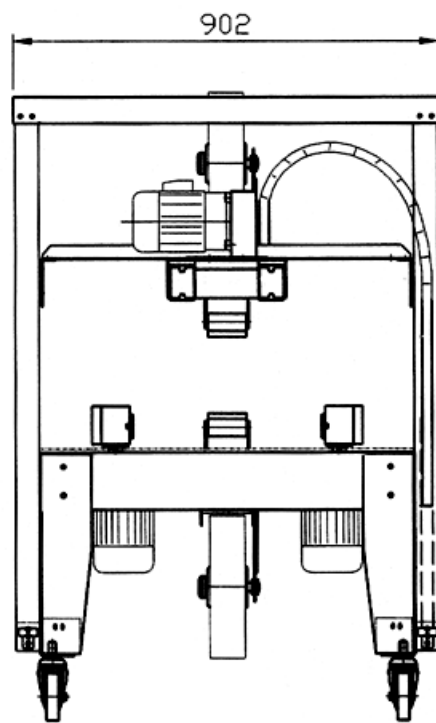

△			
NO	設 變 原 因	變 更 者	日 期

育綸實業股份有限公司

機型	EC-702A
圖名	外形尺寸圖

SPECIFICATION

The specifications & dimensions subject to change, without prior notice.

Model Name	EC-702A		Full auto random carton sealer (Top & side belt drive)
Carton Capacity	Length	6"(150mm) to infinite	
	Width	4"(100mm) to 20"(500mm)	
	Height	4"(100mm) to 20"(500mm)	
Required Air Pressure	4-6kg/cm2 or equivalent to 1HP-2HP air compressor		
Closure Material	Pressure sensitive tape width : 1 1/2 "(38mm) to 2"(50mm)/Options : 2 1/2 & 3" width tape are available		
Operating Speed	Continuous belt drive : 75ft/min (24m) Production rate depends on carton size and operator dexterity		
Electrial	110v single phase. 60HZ 3/5HP(450W) Note : other voltage are available		
Elevating Adjustable Height	10"(254mm)		
Weight	N.W :290 Lbs(132kg) G.w : 374 lbs(170kg)		
Machine Size	49 13/64 "(L) x 36 5/64 "(W) x 52 13/32 "(H) 1230(L) x 902(w) x 1310(H)mm		
Measurement	50 51/64 "(L) x 37 39/64 "(W) x 52 3/8 "(H) 1270(L) x 940(w) x 1320(H)mm		